

Copyright
 This drawing is protected by copyright & must not be reproduced in any form, including manufacture of the product shown therein, without the prior written consent of the copyright owners.
 INDUSTRIAL PENSTOCKS LTD

DO NOT SCALE - IF IN DOUBT ASK

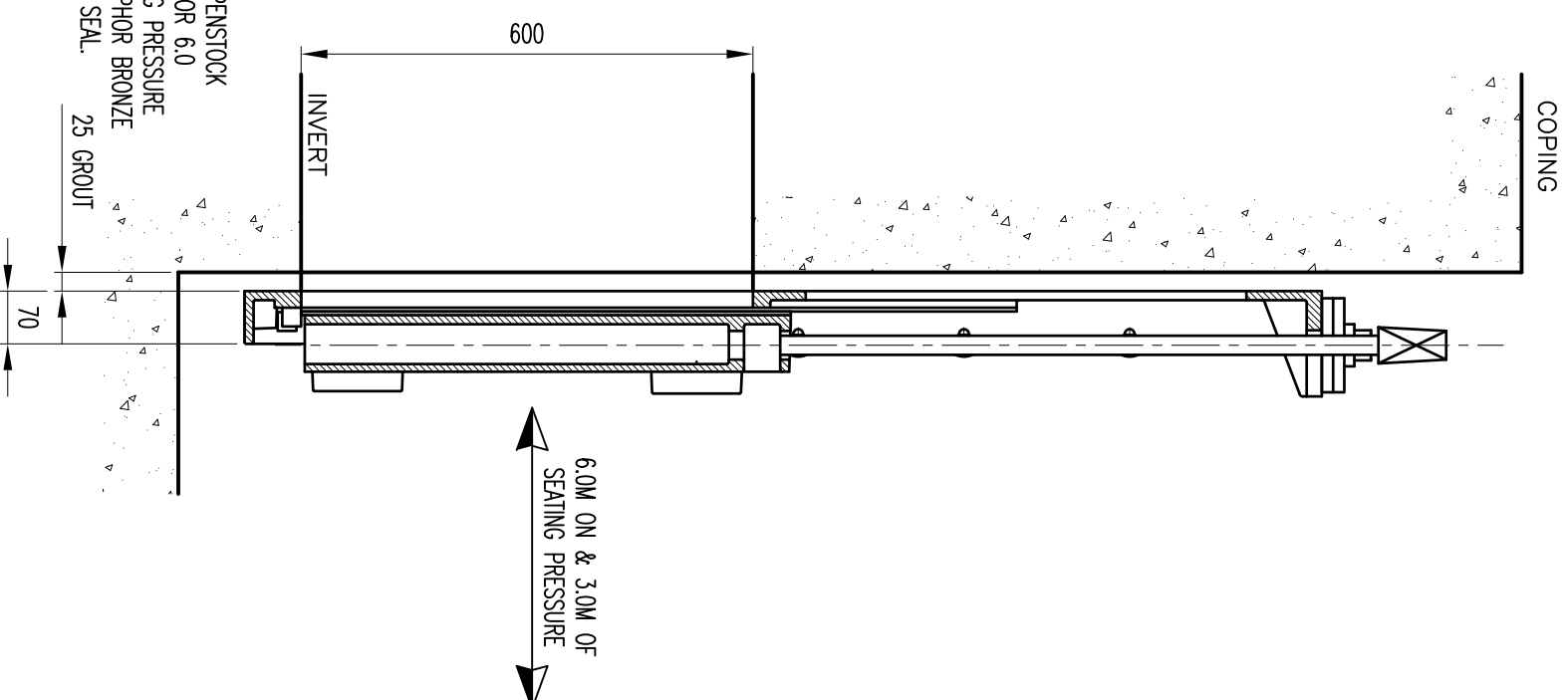
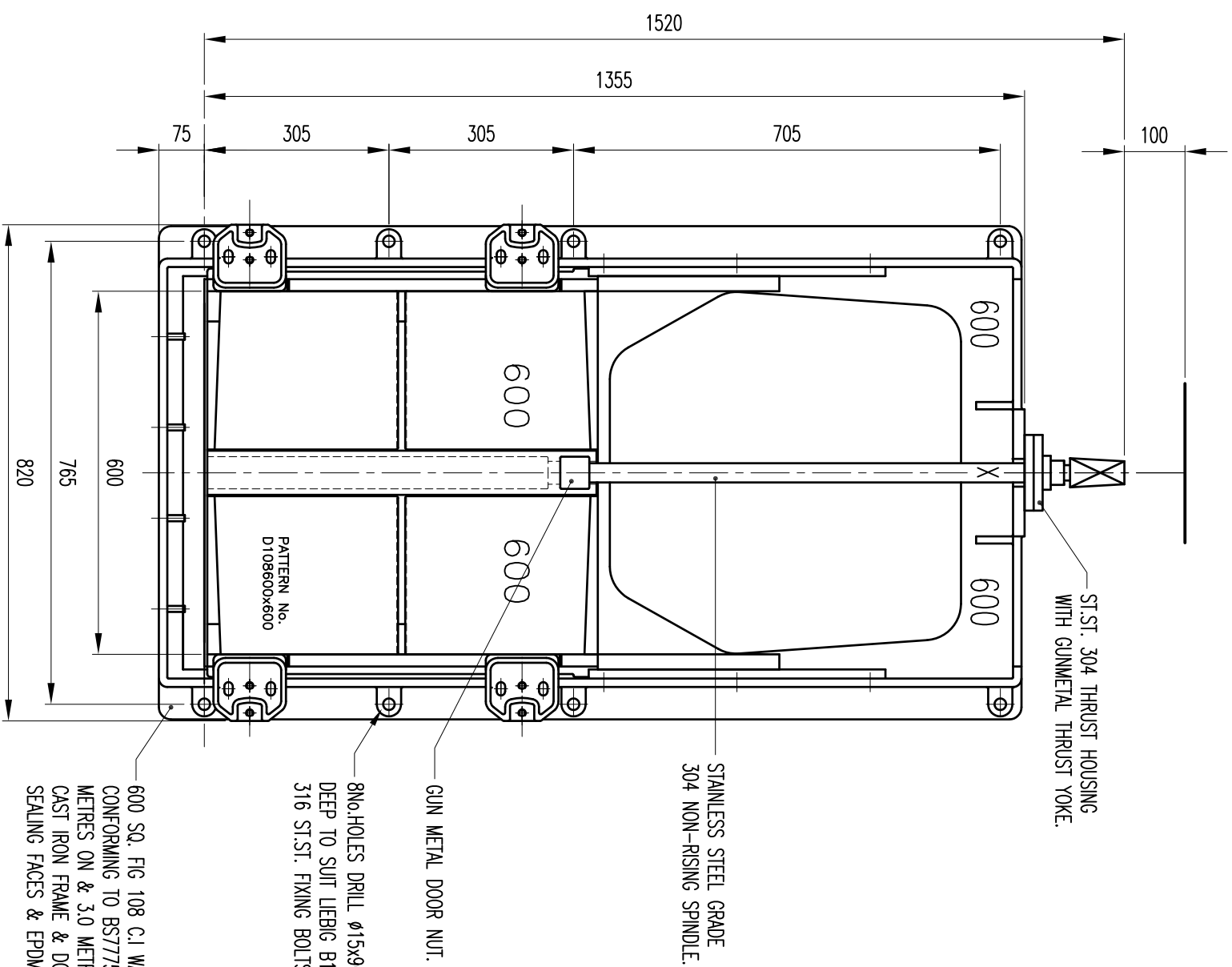

GENERAL NOTES:

- TOLERANCES UNLESS STATED OTHERWISE:
 LINEAR DIMENSIONS <1000mm= ±0.25mm
 LINEAR DIMENSIONS >1000mm= ±1.00mm
 ANGULAR DIMENSIONS= ±0.5°
 CONCENTRICITY= 0.10mm
 HOLE POSITION= 0.25mm
 PERPENDICULARITY= 0.10mm
 FLATNESS= 0.10mm
- REMOVE ALL BURRS & SHARP EDGES
- MACHINE SURFACES $\nabla_{0.8}$ UNLESS NOTED OTHERWISE.

Rev	Date	Description	By
		Amendments	

Title
GENERAL ARRANGEMENT 600 SQ. CAST IRON WALL MOUNTING PENSTOCK. TEE KEY OPERATED.

Material
 CAST IRON

Client



Industrial PENSTOCKS Ltd
 Penstocks Valves Fittings and Installation for fluid control
 Unit 142 Washington Industrial Estate, Washington Street
 Northerton, Dudley, DY2 9PH
 Tel: 01384 484111 Fax: 01384 248890

Part/Drawing Number: **600-NR-CAP DIRECT** Revision

Approved by	Checked by	Contract No
Drawn by AS	Date MAR'06	
Scales A3	1:10	Computer File No

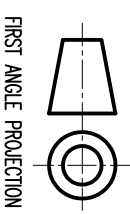

FIRST ANGLE PROJECTION